

# Quad Corner & Quad Cleat

Quad Corners and Quad Cleats are versatile products for use with four bolt connection systems.

## Quad Corner

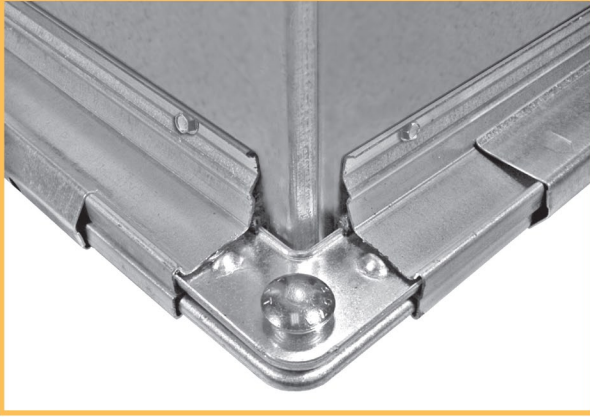

Manufactured from 16 gauge galvanized steel. Rigid design meets standards of heavier corners at a more economical price

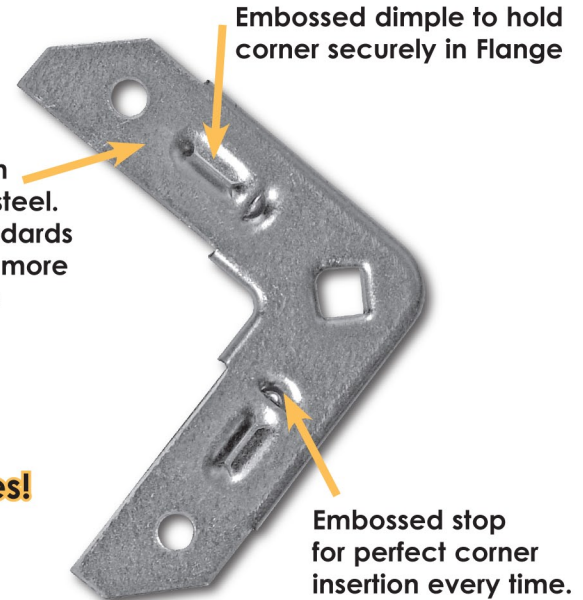

**Compatible with Dyn-O-Mate<sup>™</sup> J, Ductmate<sup>™</sup> 35, CL Ward<sup>™</sup> J, Ward Industries<sup>™</sup> J, and Hardcast<sup>™</sup> flanges!**

Other gauges and specialty metals available upon request

Item #	Code	Description	Qty Per Box.	Weight (lbs.)
21270	DDEJ	Quad Corner - 16 gauge	250	33

## Quad Cleat



Manufactured from 22 gauge galvanized steel

Embossed "darts" to securely lock the cleat firmly onto the flange connection

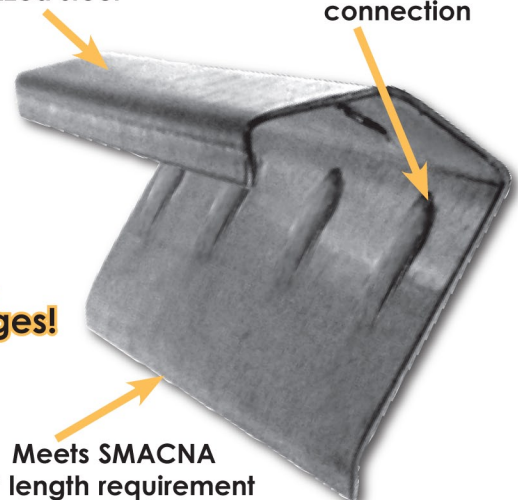

**Compatible with Dyn-O-Mate<sup>™</sup> J, Ductmate<sup>™</sup> 35, CL Ward<sup>™</sup> J, Ward Industries<sup>™</sup> J, and Hardcast<sup>™</sup> flanges!**

Other gauges and specialty metals available upon request

Item #	Code	Description	Qty Per Box.	Weight (lbs.)
21259	DOMQCLT	Quad Cleat - 6"	250' - 500 6" pcs	40