

# DuroZone

## MODEL RED-4 ZONE CONTROL SYSTEM PART# 35234

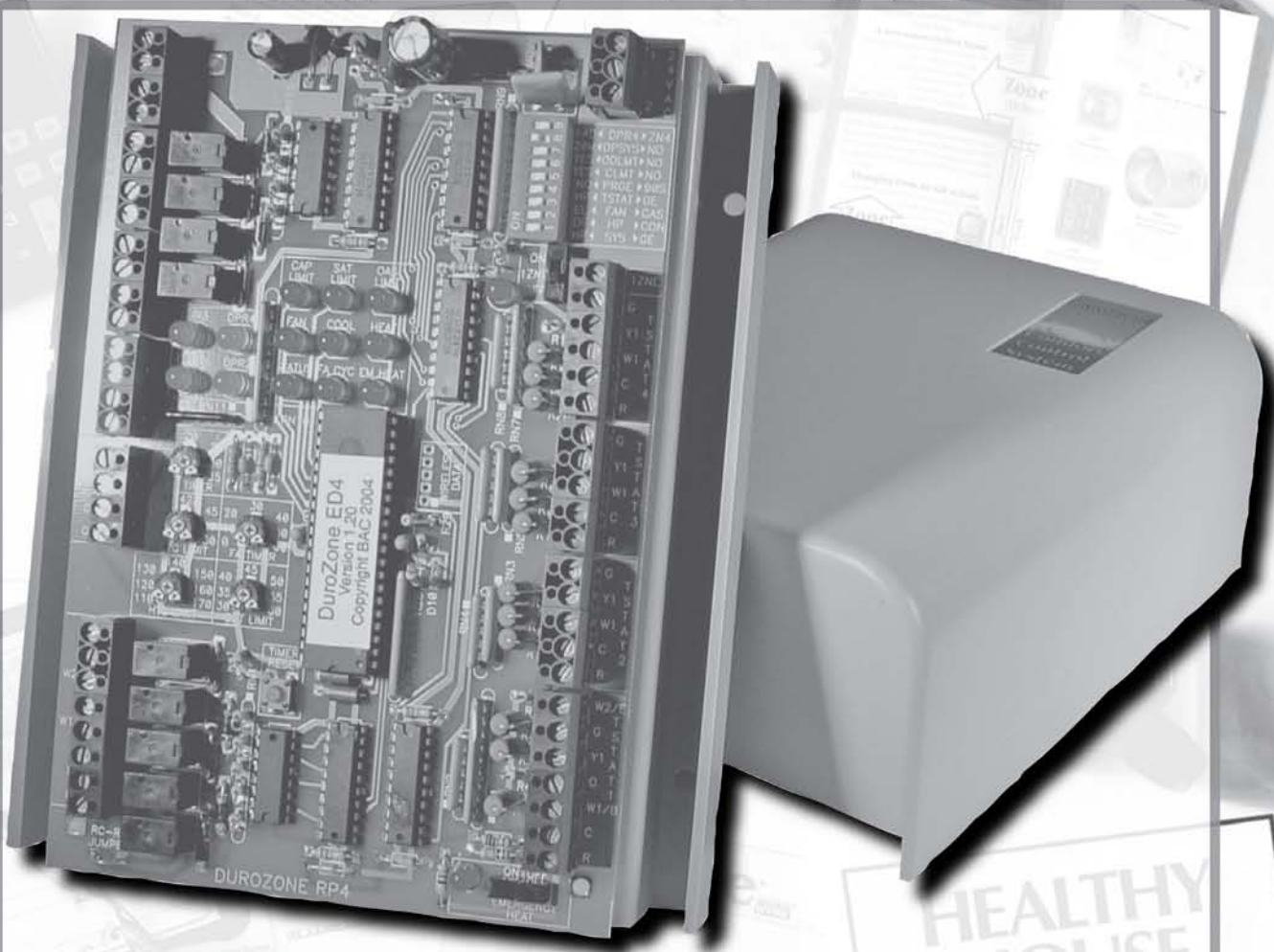

DuroZone<sup>®</sup> is a division of  
**DURODYNE<sup>®</sup>**  
Corporation

**SMZ Zone Control Packages**  
Putting together a zone control system is now easier than ever. SMZ Zone Control Packages provide, in one convenient box, all the controls, (less dampers), necessary to install a two or three zone SMZ system. Each box contains an SMZ control panel, a 24 volt 40va transformer, and the necessary thermostats for each zone. SMZ Zone Control Packages come in several configurations to address most two and three zone situations for conventional Heating/Cooling Systems and...

**HEALTHY HOUSE BUILDING**  
A DESIGN & CONSTRUCTION GUIDE  
The book every homeowner, builder, and designer needs to reduce indoor pollution and improve health.  
**JOHN BOWER**  
INTERNATIONALLY RECOGNIZED HEALTHY HOUSING EXPERT

# RED4 - Zoning Panel

## FEATURES

- Controls four zones.
- Zone4 damper can be used as fresh air damper. Timer on panel sets minutes of fresh air per hour.
- Two-stage heating and two-stage cooling for gas/electric systems and three-stage heating and two-stage cooling for heat pump systems.
- Compatible with gas/electric, oil, electric and hydronic systems and both conventional and dual fuel heat pumps. Optional supply air temperature sensor used to limit supply air temperature and prevent over-heating and freeze-up. Maximum and minimum supply air temperatures can be set on the panel.
- Optional outdoor air temperature sensor to limit use of second stage heating in moderate weather.
- Optional outdoor air temperature sensor used with dual fuel heat pumps to control switch-over to fossil fuel heating without the use of external thermostats or relays.
- Compatible with low cost, heat-cool thermostats.
- Compatible with automatic change-over thermostats allowing any zone to call for heating or cooling.
- Second and third stage startup controlled by a timer located on the panel.
- Heat pump thermostat can be used in Zone1 for emergency heat control. Optional purge cycle at the end of heating or cooling call. Limit use of second stage heating and cooling when less than half the zones are calling.
- One-Zone operation eliminates resetting all thermostats when going on vacation. All dampers and HVAC system are controlled by the Zone1 thermostat.
- Compatible with most 24VAC powered and battery powered thermostats.
- Compatible with all 24VAC damper actuators including spring return, power open and power close types.
- Automatic Contractor Test checks all wiring, dampers, thermostats and the HVAC system.

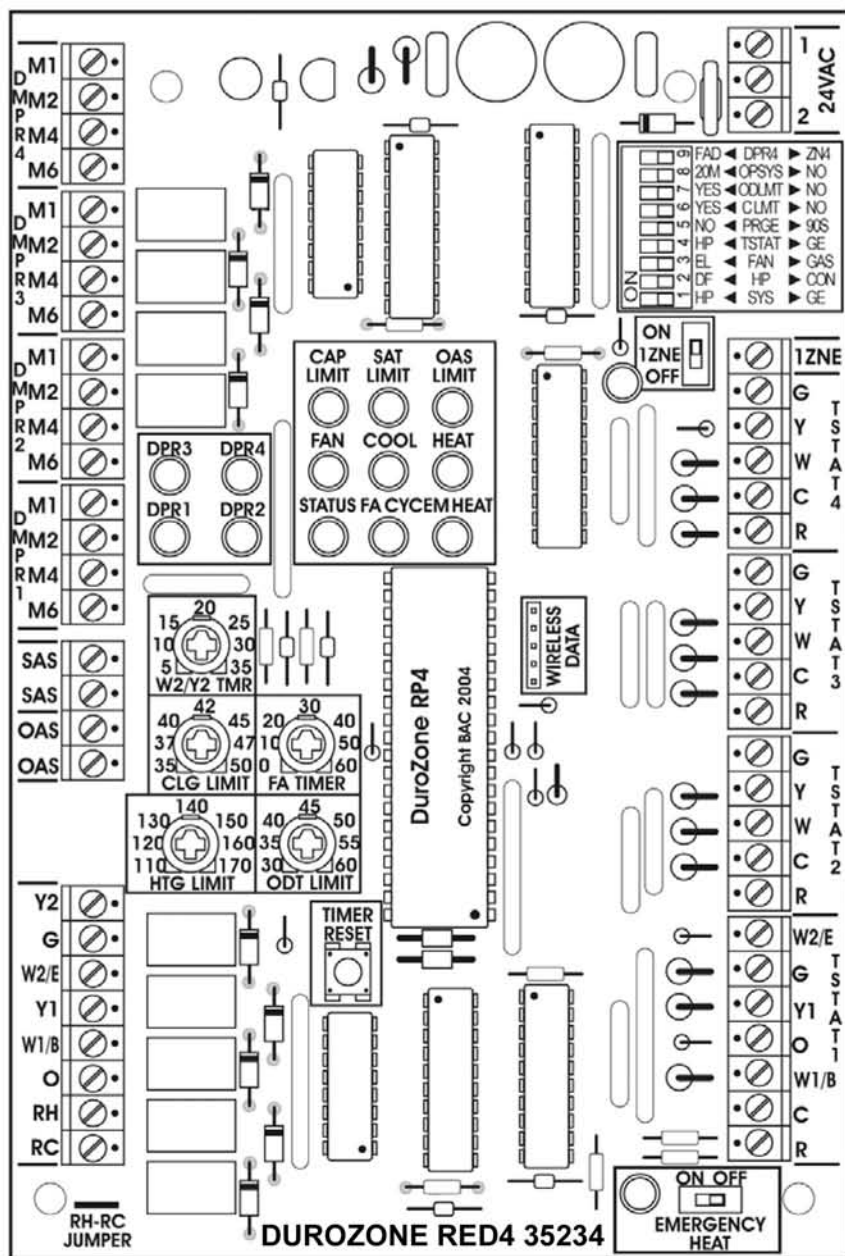

**IMPORTANT:** DuroZone recommends this control panel be mounted in a conditioned space.

# INSTALLATION INSTRUCTIONS

The RED4 is a 4-zone panel that can control gas/electric, hydronic, electric and both conventional and dual fuel heat pumps with multi-stage heating and cooling. Low cost heat-cool thermostats can be used in all zones and optionally a heat pump type thermostat can be used in Zone1.

## Selecting Equipment Options

DIP switches 1, 2 and 3 select the type of HVAC system that is being used. The panel is factory set for a Gas-Electric system with Gas Fan operation.

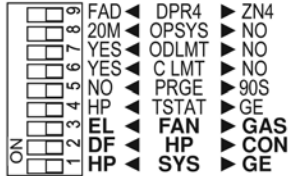

## Selecting Gas-Electric or Heat Pump System

The panel will operate with gas-electric, oil, hydronic and electric HVAC systems when DIP switch #1 is in the Off position. The panel will operate with heat pump systems when DIP switch #1 is in the On position.

## Selecting Conventional or Dual Fuel Heat Pump System

When DIP switch #1 is set to select heat pump operation, DIP switch #2 selects a conventional heat pump or a dual fuel heat pump. For conventional heat pumps the panel will activate stage one and two compressors (Y1 and Y2). In third stage heating the panel will activate both compressors and the auxiliary heating (W2). For dual fuel heat pumps only the auxiliary heating (W2) is activated during third stage heating calls.

## Selecting Gas or Electric Fan Operation

DIP switch #3 selects Gas or Electric Indoor Fan operation. In Gas mode the fan is not turned On by the panel during a heating call. A sensor or timer in the furnace will automatically turn the fan On.

In Electric operation, the panel turns the fan On during heating calls. Selecting a heat pump system will automatically turn the fan On during heating calls. If a dual fuel heat pump is used, DIP switch #3 selects whether the fan is operated during calls using the auxiliary fuel system for heating.

In both Gas-Electric and Heat Pump Systems, the indoor fan is activated during cooling calls.

## Selecting Type of Thermostat in Zone1

DIP switch #4 selects the type of thermostat being used in Zone1. For heat pump systems, a heat pump thermostat may be selected for Zone1 to provide emergency heat control on the thermostat. When using a heat cool thermostat for heat pump systems the emergency heat can be controlled by the

Emergency Heat slide switch on the panel or an external switch. Do not use the panel switch or the external switch if Dip switch #4 is set to HP.

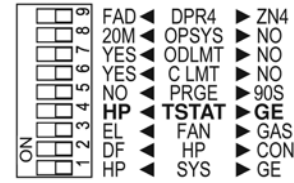

## Selecting Purge Control

DIP switch #5 selects whether the heat or cool stored in the system at the end of a heating or cooling cycle is purge by the panel. If purge is controlled by the panel, the indoor fan will be operated for 90 seconds at the end of the call to purge the system. During purge the dampers will remain in the position just before purge and purged air goes to the last zones calling.

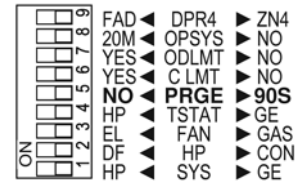

## Selecting Capacity Limit Control

DIP switch #6 selects whether second stage heating or cooling will be inhibited if only half the zone(s) are calling for heating or cooling.

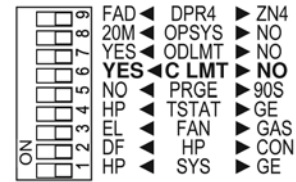

## Selecting Outdoor Temperature Limit Control

DIP switch #7 selects whether stage two heating will be disabled if the outdoor temperature is above the temperature set on the ODT Limit potentiometer. In dual fuel heat pumps, switch #7 selects if the heat pump automatically switches to the auxiliary heating system when the outdoor temperature drops below the temperature set on the ODT Limit potentiometer.

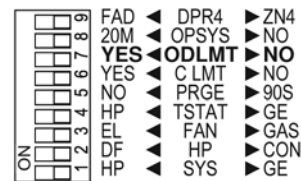

## Selecting Opposite System Service

The panel will normally service heating or cooling based on whether there are more heating or more cooling calls.

If Opposite System service is selected using DIP switch #8, the panel will switch to the opposed system after calling continuously for 20 minutes even though there may be only one zone calling for the opposed system.

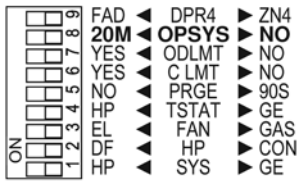

## Selecting Use of Zone4 Damper

Dip switch #9 selects whether Damper4 is being used as Zone4 damper or as a fresh air damper. When used as a fresh air damper, the minutes per hour of fresh air is set on the panel.

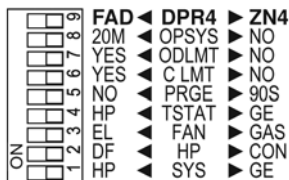

## Selecting One-Zone Operation

The panel can be operated as a single (one-zone) system. The panel will control all the dampers together based on the Zone1 thermostat.

This can eliminate the need to change all the thermostats when the home or building is vacant such as at night or during vacation periods.

One-Zone operation can be selected using the 1ZNE switch on the panel or an external switch. The LED adjacent to the switch will be activated when One-Zone operation is selected.

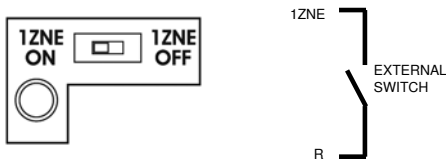

## Emergency Heat Operation

Emergency Heat can be selected from Zone 1 when using a heat pump thermostat. When using a conventional heat cool thermostat the Emergency Heat can be selected on the panel switch or an external switch. If emergency heat is activated by the panel switch or an external switch, the LED adjacent to the switch will be lit. Any heating calls from any thermostat will be treated as emergency heat calls.

The emergency heat switch on the panel or an external switch cannot be used when Dip switch #4 is set to heat pump thermostat. The emergency heat switch on the thermostat must be used in this mode.

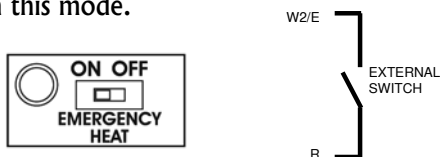

If an emergency heat call is initiated by a heat pump thermostat in Zone1, an emergency heat call will occur. The panel will treat all calls for heating as emergency heat calls until Zone1 calls for a non-emergency heat call or a cooling call.

## Timer Reset Switch

Momentarily pressing the Timer Reset switch clears the built-in timers allowing the system to be checked out more quickly. Holding the Timer Reset switch for 10 seconds will activate the Automatic Contractor Test that checks the system out completely. The Automatic Contractor Test is described later.



## 24VAC Power

24VAC is connected to the panel at the terminals marked 24VAC. A 40VA transformer should be used and the output connected to terminals 1 and 2 (not polarized). A circuit breaker type fuse is located next to the terminals. If a short should occur in the damper or thermostat wiring, the Fuse will open the circuit and then close the circuit when the short is removed.

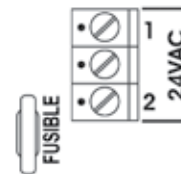

**WARNING! THE FUSE GETS VERY HOT WHEN A SHORT OCCURS AND SHOULD NOT BE TOUCHED.**

**PLEASE NOTE: YOU MUST USE AN INDEPENDENT LOW VOLTAGE POWER SUPPLY.**

## Wireless Data Connector

This connector is provide for future wireless thermostats and wireless connection to a PC computer that can be used to monitor the zoning system.



## Heating Limit Potentiometer

This potentiometer sets maximum Supply Air Plenum temperature allowed in heating. A low cost Supply Air Sensor can be used to monitor the temperature and if the supply air temperature exceeds the set Heating Limit, the heat is turned off and the indoor fan activated. After two minutes the heat will be turned back on if the supply air has dropped below the Heating Limit.

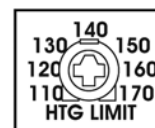

## Cooling Limit Potentiometer

This potentiometer sets minimum Supply Air Plenum temperature allowed in cooling. If the supply air temperature drops below the set Cooling Limit, the cooling is turned off and the indoor fan activated. After two minutes the cooling will be turned back on if the supply air has risen above the Cooling Limit.



## W2/W3/Y2 Timer Potentiometer

Second and third stage heating and second stage cooling are controlled by a timer. If the panel has been calling for heating or cooling longer than the time set on the W2/W3/Y2 Timer potentiometer, the second stage heating or cooling will be activated provided it is not inhibited by the Outdoor Temperature Limit or the Capacity Limit. If the panel has been calling for second stage heating longer than the time set on the W2/W3/Y2 Timer Potentiometer, the Third Stage Heating will be activated provided it is not inhibited by a limit.

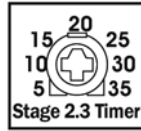

## ODT Limit Potentiometer

A low cost Outdoor Air Sensor can be used to monitor the outdoor temperature and if the outdoor temperature is greater the ODT Limit, second stage heating is inhibited if the option was selected.

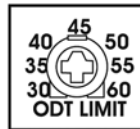

In a dual fuel heat pump, the ODT Limit is used to automatically switch the panel to the auxiliary heating system.

## FA Timer Potentiometer

When Damper4 is used as a fresh air damper, the minutes of fresh air per hour can be set on the FA Timer potentiometer. The fresh air minutes will try to be fulfilled during a heating or cooling call. If the fresh air minutes cannot be fulfilled during a call, Damper4 will be opened and the indoor fan will be activated.

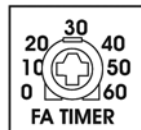

## Damper LEDs

The green damper LEDs will light when the damper is in the open position. A damper LED will blink if it detects a zone thermostat is calling for both heating and cooling that may be caused by a shorted wire.

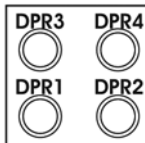

## System LEDs

The nine red LEDs indicate the status of the HVAC system. Each LED will indicate by being lit continuously or blinking.

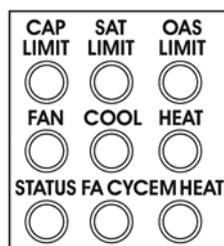

## Fan LED

The Fan LED will be lit continuously when the panel is in continuous indoor fan operation. The Fan LED will blink when the system is in Purge mode.



## Cool LED

The Cool LED will be lit continuously when the panel is calling for first stage cooling. The Cool LED will blink when the panel is calling for second stage cooling.



## Heat LED

The Heat LED will be lit continuously when the panel is calling for first stage heating. The Heat LED will blink when the panel is calling for second stage heating.



## Status LED

The Status LED blinks continuously when the panel is powered and indicates the microprocessor is operating properly. If the Status LED is on and not blinking, the automatic contractor test is in progress.



## SA Limit LED

The SA Limit LED is on continuously when a Supply Air Sensor is installed. The SA Limit LED blinks when the panel is in supply air limit status (Heating or Cooling temperature exceeded).



## ODT Limit LED

The ODT Limit LED is on continuously when an Outdoor Air Sensor is installed. The ODT Limit LED blinks when the panel is inhibiting second stage calls because of ODT Limit or the dual fuel heat pump has switched to the auxiliary heating system.



## Capacity Limit LED

The Capacity Limit LED is on continuously when the panel is inhibiting second stage calls because only one zone is calling for heating.



## Emergency Heating LED

The Emergency Heating LED is on continuously when the panel is in the emergency heat mode and will blink during an emergency heat call.



## Fresh Air Cycle LED

The FA Cycle LED is on continuously when the fresh air damper mode is selected and blinks when the damper is opened for fresh air.



## Wiring Instructions

All wiring should be done in accordance with local and national codes. Use color-coded, multi-conductor thermostat wire.

**THESE PANELS ARE DESIGNED FOR USE WITH 24VAC CONTROLS AND SHOULD NOT BE USED WITH OTHER VOLTAGES. USE CAUTION TO AVOID ELECTRIC SHOCK OR DAMAGE TO EQUIPMENT.**

### Wiring Supply Air Sensor

To install the optional Supply Air Sensor, connect two wires to the Supply Air Sensor and to the two terminals marked "SAS" on the panel.

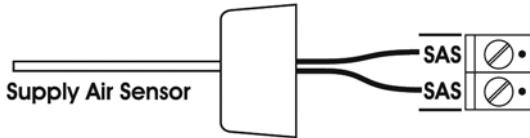

The Supply Air Sensor should be installed in the Supply Air Plenum so that it measures the supply air temperature.

### Wiring Outdoor Air Temperature Sensor

To install the optional Outdoor Air Temperature Sensor, connect two wires to the Outdoor Air Sensor and to the two terminals marked "OAS" on the panel.

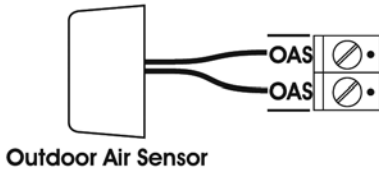

The Outdoor Air Temperature Sensor should be installed outside and in a shaded location.

### Wiring Zone Thermostats

All zones can use low cost, heat-cool thermostats as shown below. Be sure to set DIP switch #4 to HC if a heat-cool thermostat is used in Zone1.

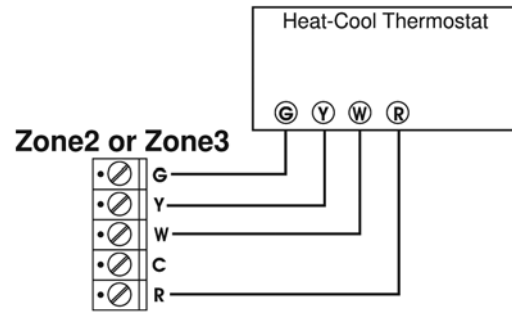
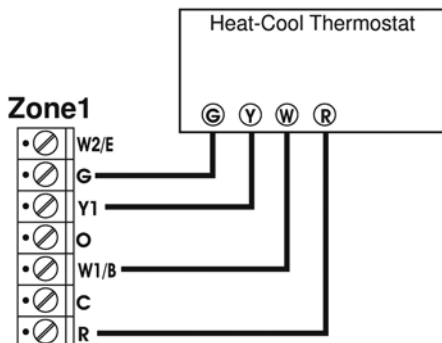

A heat pump thermostat can be used in Zone1 to provide emergency heat control from the thermostat. Be sure to set DIP switch #4 to HP.

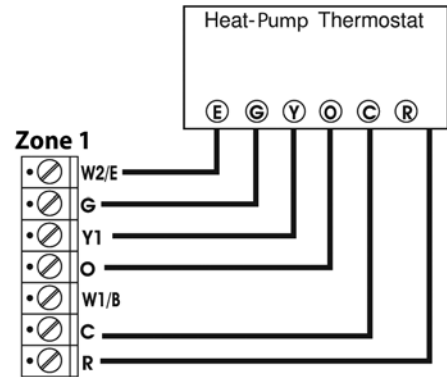

### Wiring Dampers

The panel can be used with any 24VAC power open/power close or spring return damper. Terminal M1 is 24VAC common, M2 is 24VAC, M4 is 24VAC when the panel opens the damper and M6 is 24VAC when the panel closes the damper.



Wiring diagram for DuroZone MB, MS, or RD type damper.

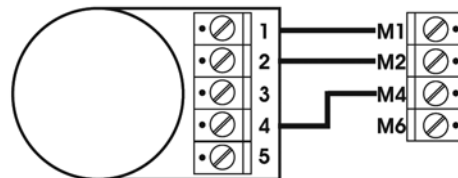

Wiring diagram for a spring return damper that is normally closed with no power (spring closed).

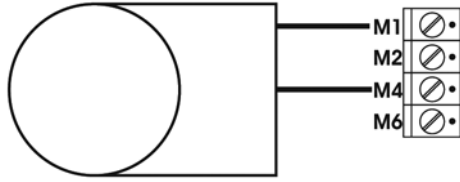

Wiring diagram for a spring return damper that is normally open with no power (spring open).

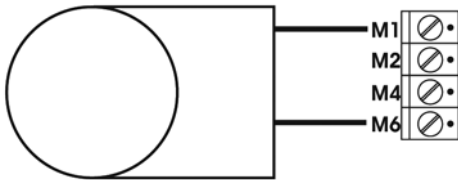

### Wiring HVAC System

The panel can be used with a wide variety of HVAC systems. Some of the more common configurations follow:

**PLEASE NOTE: THE RED4 PANEL MUST BE POWERED BY AN INDEPENDENT LOW VOLTAGE POWER SUPPLY AND NOT BY THE EQUIPMENT LOW VOLTAGE POWER SUPPLY.**

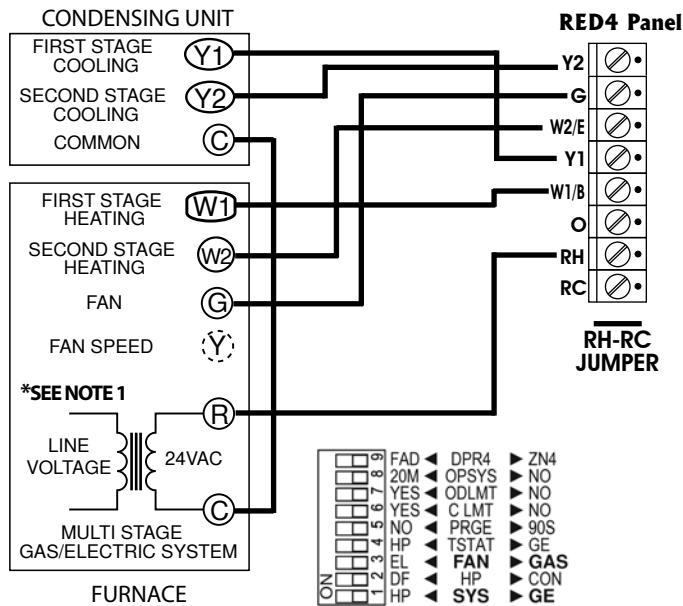

**\*NOTE 1:** Sometimes Y needs to be wired to the furnace for fan speed.

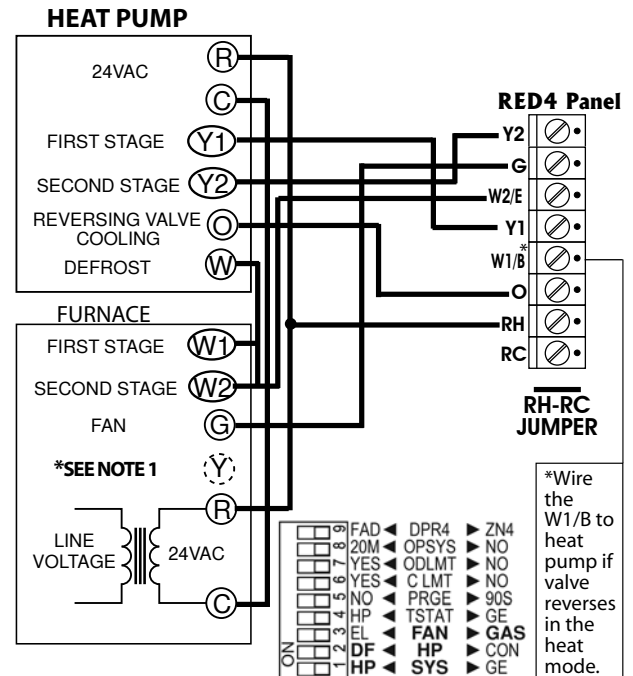
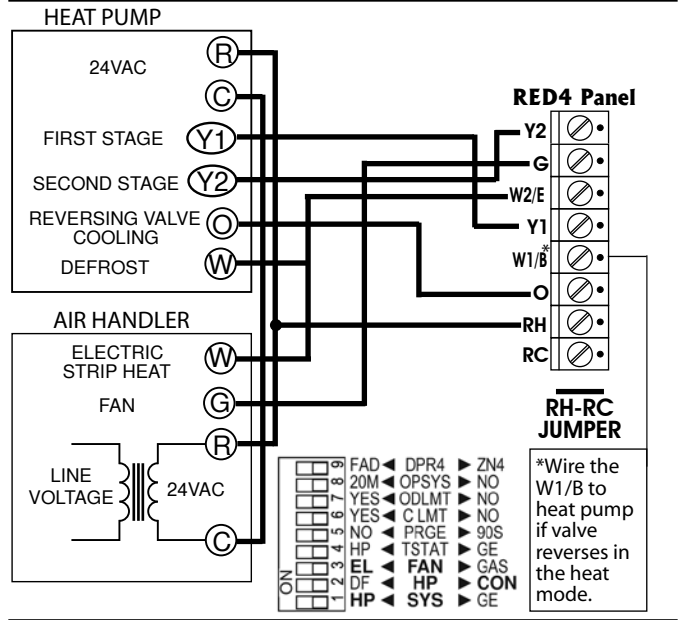
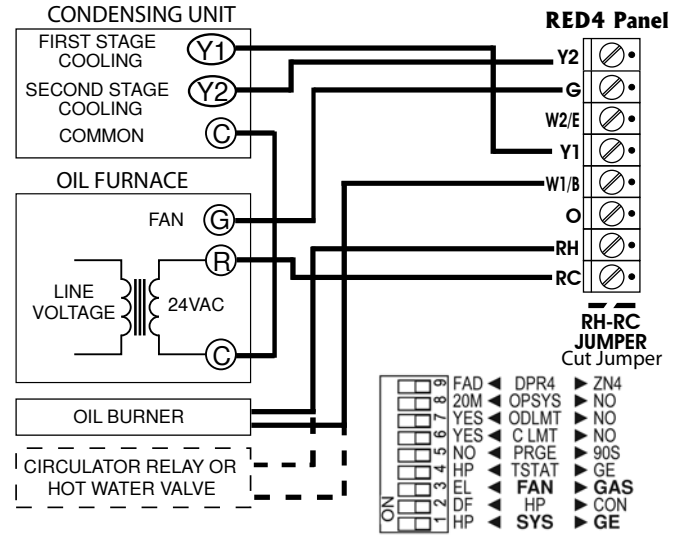

**\*NOTE 1:** Sometimes Y needs to be wired to the furnace for fan speed.

## Automatic Contractor Test

The Automatic Contractor Test (ATC) can be started at any time by pressing and holding the Timer Reset switch for 10 seconds. The test can be terminated at any time by pressing the Timer Reset switch again.



Before the test is started all calls are terminated and all dampers are closed. The Status LED will be on continuously during the test.

### Step1. Zone1 Thermostat Test

The DPR1 led will turn On and the Cool, Heat, Fan, or EM Heat LED will turn On indicating the state of the Zone1 thermostat. If the Cool, Heat, Fan and EM Heat LEDs are all Off, there is no call at the thermostat.

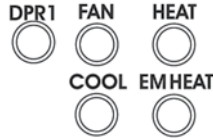

### Step2. Zone2 Thermostat Test

After a 1 minute delay, the DPR2 led will turn On and the Cool, Heat, Fan, or EM Heat LED will turn On indicating the state of the Zone2 thermostat.

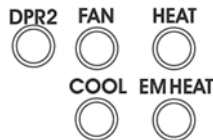

### Step3. Zone3 Thermostat Test

After a 1 minute delay, the DPR3 led will turn On and the Cool, Heat, Fan, or EM Heat LED will turn On indicating the state of the Zone3 thermostat.

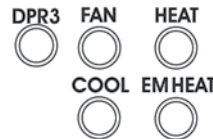

### Step4. Zone4 Thermostat Test

After a 1 minute delay, the DPR4 led will turn On and the Cool, Heat, Fan, or EM Heat LED will turn On indicating the state of the Zone4 thermostat.

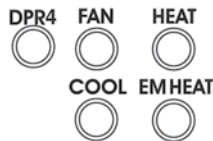

### Step5. Damper Test

All dampers will be opened and the indoor fan activated for 1 minute.



You can terminate the test at this time by pressing the Timer Reset switch. You might want to change the thermostats and again run the test.

### Step6. Damper4 Test

After a 1 minute delay, the Damper1 will be opened and the indoor fan activated. You should feel airflow at Zone1 but not at the other zones. The DPR1 LED will be On.



### Step7. Damper3 Test

After a 1 minute delay, the Damper2 will be opened and the indoor fan activated. You should feel airflow at Zone2 but not at the other zones. The DPR2 LED will be On.



### Step8. Damper2 Test

After a 1 minute delay, the Damper3 will be opened and the indoor fan activated. You should feel airflow at Zone3 but not at the other zones. The DPR3 LED will be On.



### Step9. Damper1 Test

After a 1 minute delay, the Damper4 will be opened and the indoor fan activated. If Damper4 is used as a zone damper you should feel airflow at Zone4 but not at the other zones. The DPR4 LED will be On. If Damper4 is used as a fresh air damper you should check the intake air. should check the intake air.



### Step10. Stage1 Heating Test

After a 1 minute delay, all dampers will be opened and the stage1 heating activated. Check that heated air is entering the zones. The Heat LED will be On continuously.



### Step11. Stage2 Heating Test

After a 2 minute delay, the stage2 heating is also activated. Check that heated air is entering the zones. The Heat LED will be blinking.



### Step12. Stage3 Heating Test

If a heat pump is selected, the third stage heating will be activated for 2 minutes. The heating will be turned Off and the indoor fan run for 2 minutes to purge the heat. The Fan LED will blink during the purge cycle.



### Step13. Stage1 Cooling Test

The Stage1 cooling is now turned On and Cool LED will be On. Check that cool air is entering the zones.



### Step14. Stage2 Cooling Test

After 2 minutes the Stage2 cooling is also turned On and Cool LED will blink. Check that cool air is entering the zones.



After the stage2 cooling has run for 2 minutes the cooling will be turned Off. The indoor fan will run for 2 minutes to purge the cooling. The Fan LED will blink during the purge and after 2 minutes the panel will return to normal operation.



©2009 Duro Dyne Corporation  
Printed in USA 10/2009  
BPO35428

Duro Dyne East Division, Bay Shore, NY

631-249-9000 Fax: 631-249-8346

Duro Dyne Midwest Division, Fairfield, OH

513-870-6000 Fax: 513-870-6005

Duro Dyne West Division, Santa Fe Springs, CA

562-926-1774 Fax: 562-926-5778

Duro Dyne Canada, Lachine, Quebec, Canada

514-422-9760 Fax: 514-636-0328

www.durodyne.com E-mail: durodyne@durodyne.com